

Tiree Regatta Club Boat Data Form

Below is a basic form that should enable us to update our records of your craft as well as provide you with an accurate handicap for racing. Please try fill in as much information as you can to be as accurate as you can with the data you supply if you have any problems with any of the terms or measurements please contact one of the comitee or Sam Bouchnak on 01879220420.

General information			
Boat Name		Boat Type	
Builder		Date Built	
Designer		Construction	
Rig		Engine	
Propeller Type	fixed/folding/none	Sail No /OGA No	
Owner		Home port	
Contact Details / address		VHF Call Sign	
Other information of interest:			
Please continue on additional sheet			
Colours			
Mainsail		Hull	
Jib		Racing Flag	
Staysail			
Topsail			
Hull Measurements in feet			
LOA (Hull only)		Beam	
Length (berthing)		Draft	
LWL		Centre Plate	
Rig Details in feet			
Main Sail¹	luff	head	foot
Topsail	luff	perpendicular	
Mizzen	luff	head	foot
Fore Triangle²	height	length	

¹ Bermudan boats ignore "head" measurement on mainsail

² Fore Triangle is measured from highest jib sheave to deck, no account is taken of actual foresails.

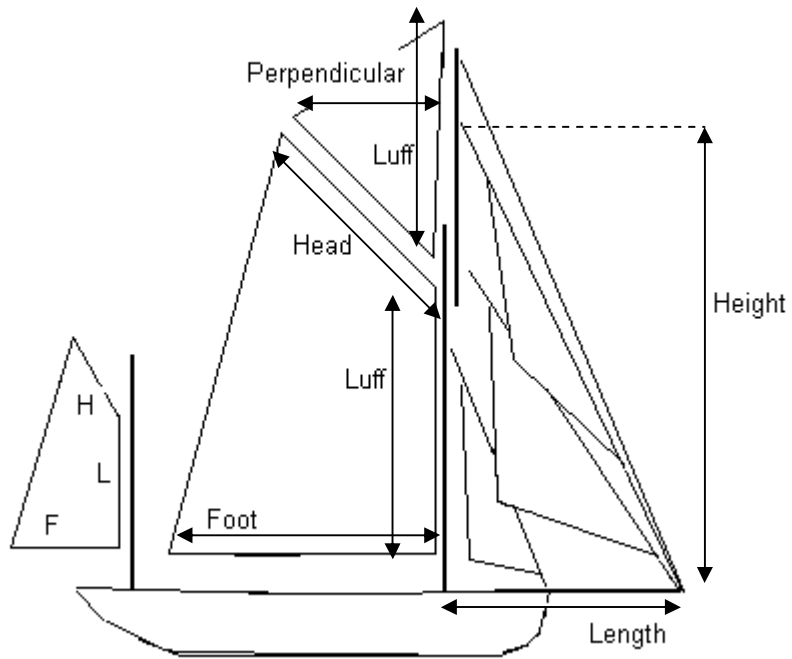

Tips: Take the measurements from your sails for mains'l, tops'l and miz'n. For the fore triangle measure highest jib sheave to deck, and bowsprit sheave to mast.

